

<b>Order code</b>	<b>Manufacturer code</b>	<b>Description</b>
18-3687	n/a	4 X AA BATTERY HOLDER KEYSTONE 2477 (RC)

	Page 1 of 2
The enclosed information is believed to be correct, Information may change without notice due to product improvement. Users should ensure that the product is suitable for their use. E. & O. E.	Revision A 20/02/2007

THIS DOCUMENT IS THE PROPERTY OF KEYSTONE ELECTRONICS CORP. AND SHALL NOT BE REPRODUCED, DISTRIBUTED OR USED AS A BASIS FOR MANUFACTURE WITHOUT PRIOR WRITTEN PERMISSION FROM KEYSTONE ELECTRONICS CORP.

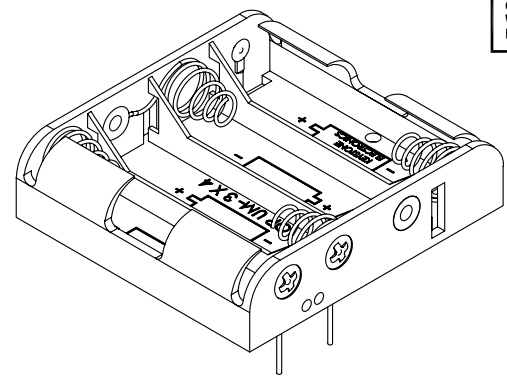
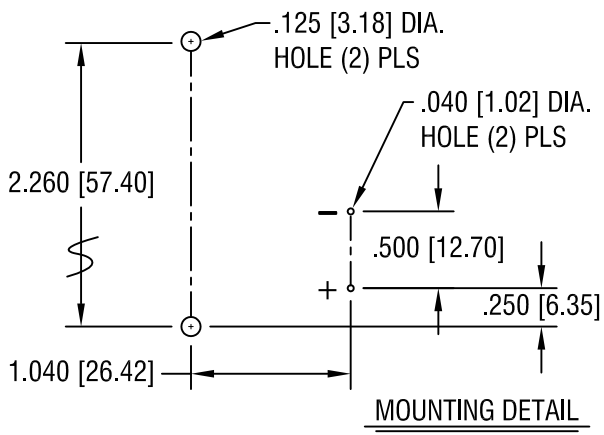

±.005 [±0.15]

.115 [2.92] DIA. HOLE (2) PLS

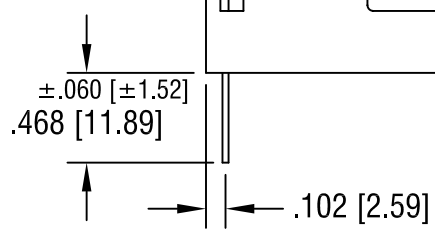
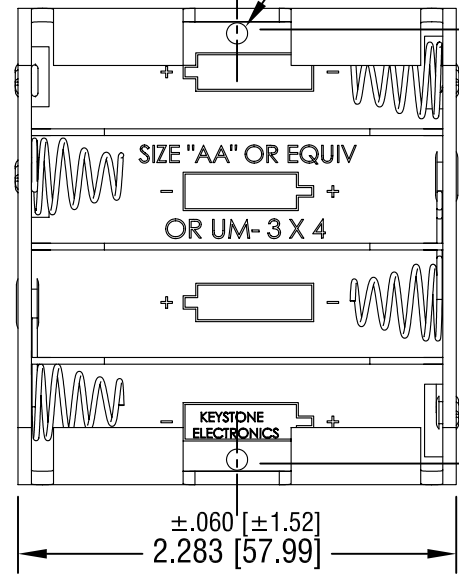
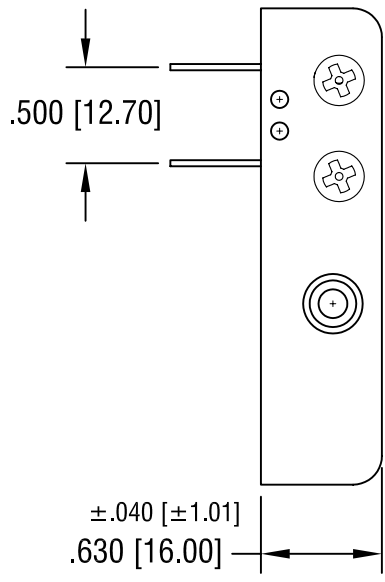

**NOTE:**  
 1. HOLDER: MAT'L: POLYPROPYLENE  
 SPRING: MAT'L: MUSIC WIRE, .027 [0.70] DIA.  
 PC TERMINALS: MAT'L: BRASS, .032 [0.81] DIA.

<b>KEYSTONE ELECTRONICS CORP.</b>			
ASTORIA, N.Y. 11105-2017			
PART NAME		PC BATTERY HOLDER (4) 'AA'	
MATERIAL			
AS NOTED			
FINISH		DRN BY	DATE
NICKEL PLATE		BOONE	3.1.99
		APP'D	SCALE
		LN	1X
TOLERANCES	INCH [MM]	CODE	DWG NO.
DECIMAL	± .015 [± 0.38]	C/M	<b>2477</b>
ANGULAR	± 1°		
UNLESS OTHERWISE SPECIFIED			

9.13.08	CHANGE AS PER ECN 08-154	D
7.14.03	CHANGE AS PER ECN 03-044	C
4.7.03	CHANGE AS PER ECN 03-028	B
11.10.99	CHANGE AS PER ECN 99-082	A
DATE	DESCRIPTION	REV.